



A R K T U R A

# Trace<sup>®</sup> Skew



---

Ceiling & Wall **Panels**



# Inspiration



**Trace® Skew Brings Visual Interest to Your Space**



**Integrate Acoustic Control with Soft Sound® Backers**



**Add Subtle Texture**

# Overview

- 1 Understanding the System
- 2 Optional Accessories
- 3 Available Finishes
- 4 Product Specifications

## 1 Understanding the System

### Standard Panel

Trace® is a modular accessible aluminum panel system designed to work with torsion grid. Customization is available.

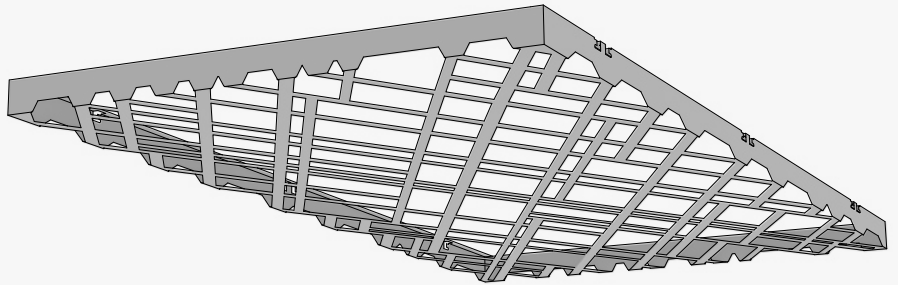

### Seamlessly Join Walls & Ceilings

Trace® easily transitions from one plane to another and around corners.

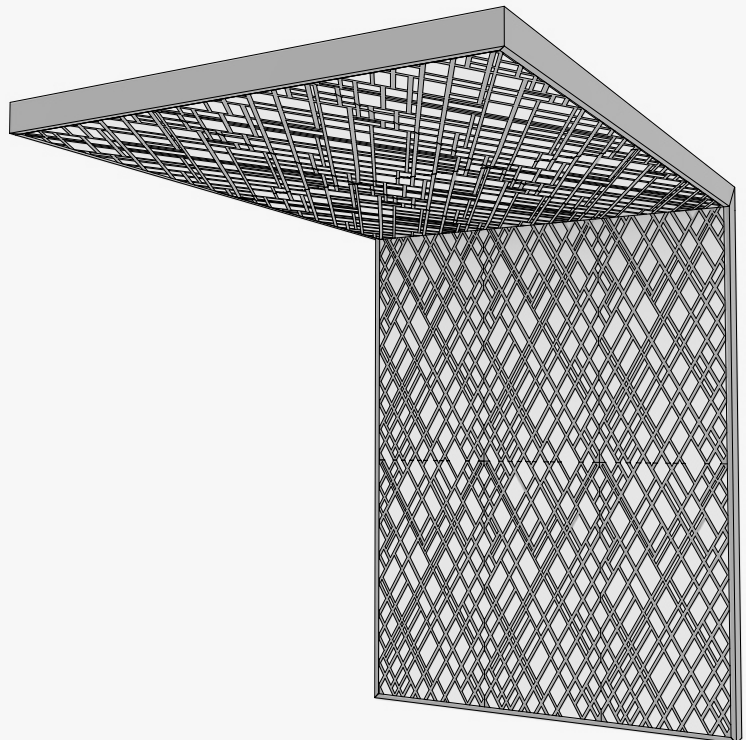

# 1 Understanding the System

## Understanding the Panel

The pattern surface is created using 4 unique tiles in a specific arrangement that minimizes visual repetition across your space.

Panel A: 62% Open

\*Vertika® Trim

Ceiling Section

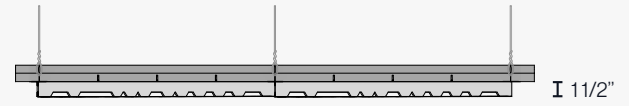

Panel Configuration, Wall or Ceiling

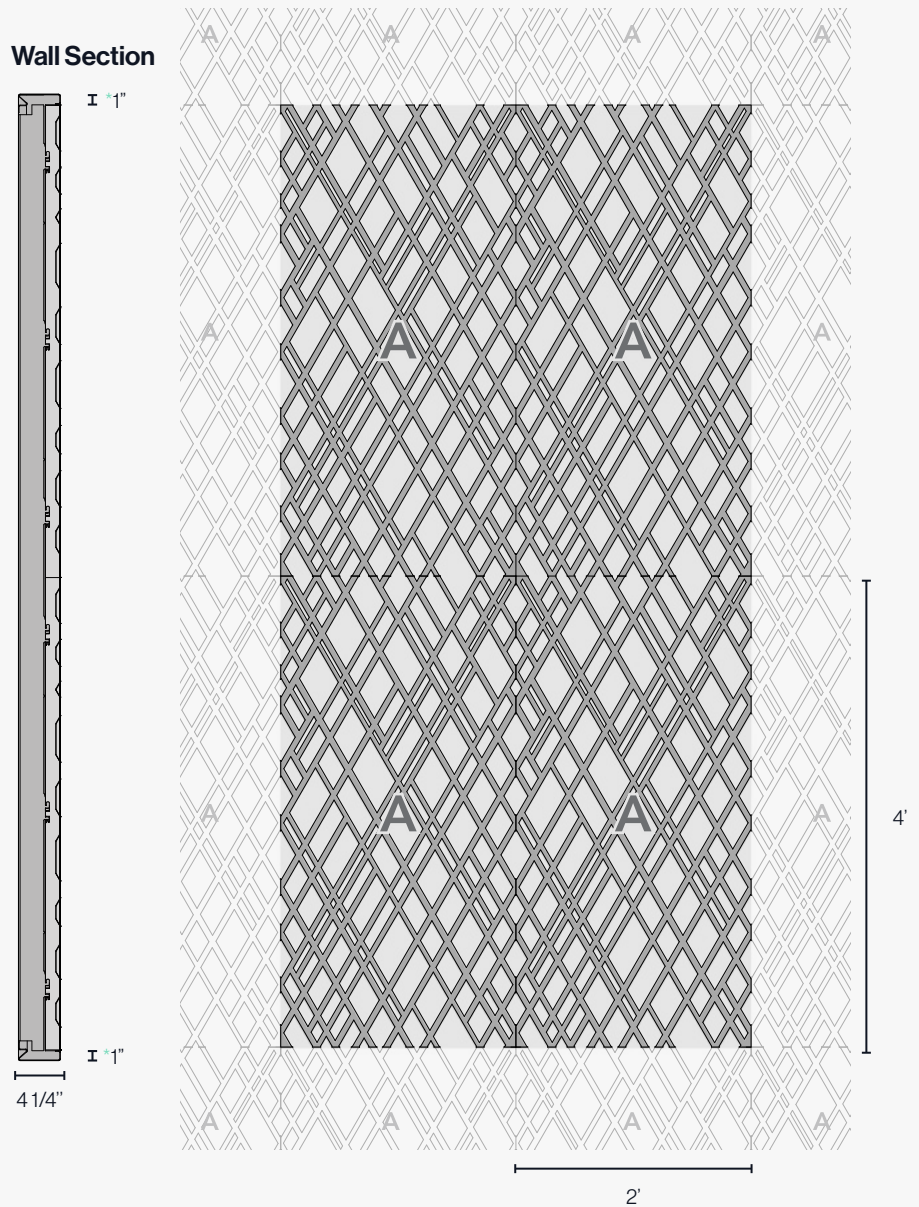

! All dimensions nominal.

# 1 Understanding the System

## Accessory Options - Ceiling

- Frosted light diffusing backer
- 1/2" acoustic backer
- Backlight
- InLine downlight

**i** Check out our Configuration examples on PAGE 10.

\* A Specific Inline light panel is used to accommodate the width of the fixture within the 2' width.

### Torsion Spring Adapter Clip

Interested in using standard t-grid? Use our Torsion Spring Adapter Clip.

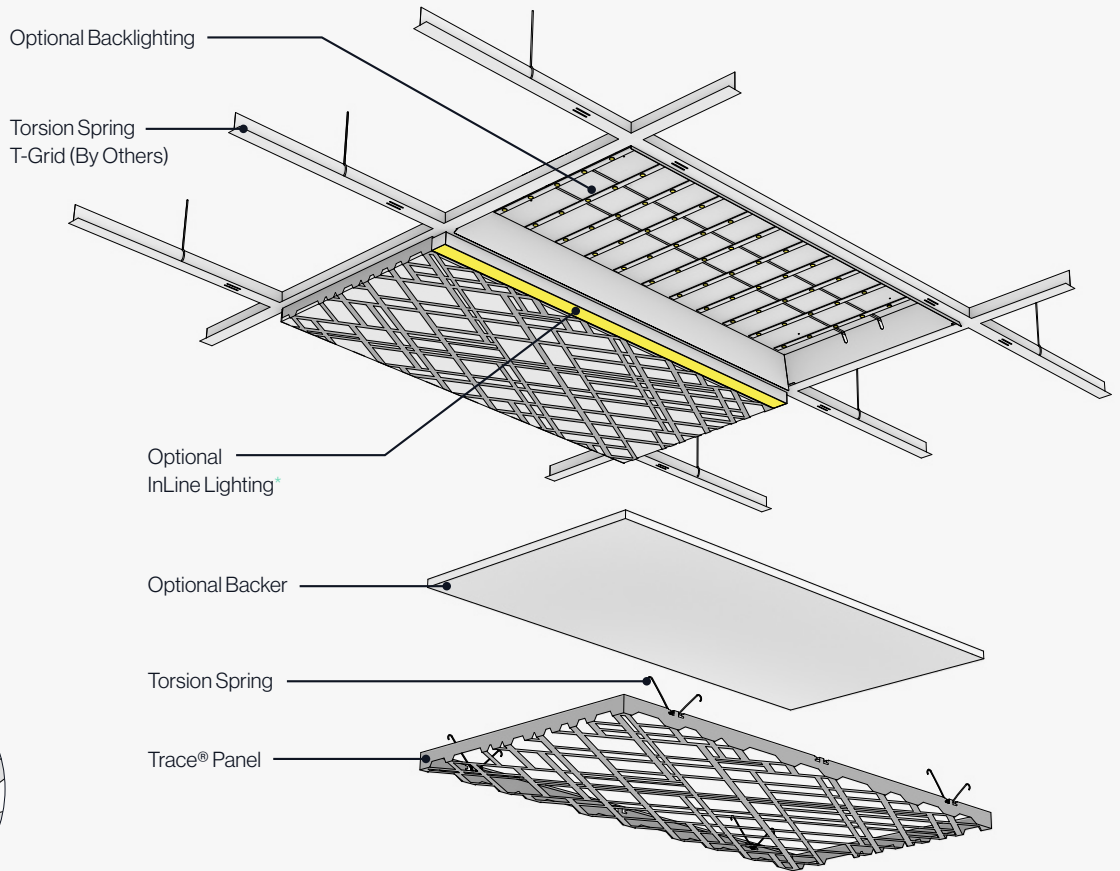
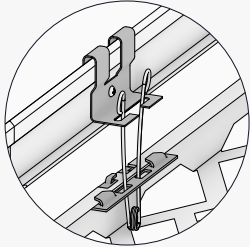

## Attachment System - Ceiling

Torsion Spring clips allow for rapid install and easy access for maintenance above the grid post install.

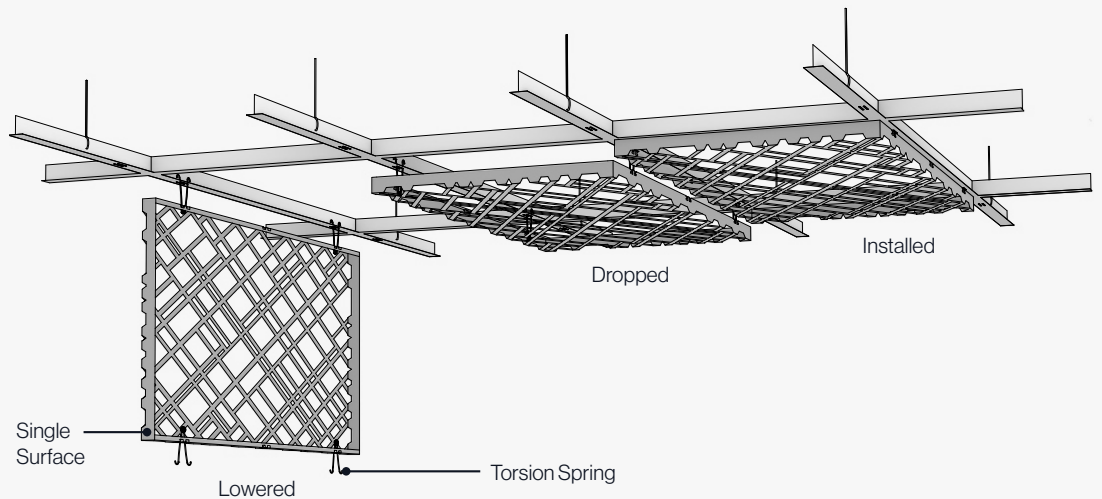

# 1 Understanding the System

## Accessory Options - Wall

- Frosted light diffusing backer
- 1/2" acoustic backer
- Backlight
- InLine light

**i** Check out our Configuration examples on PAGE 10.

\* A Specific Inline light panel is used to accommodate the width of the fixture within the 2' width.

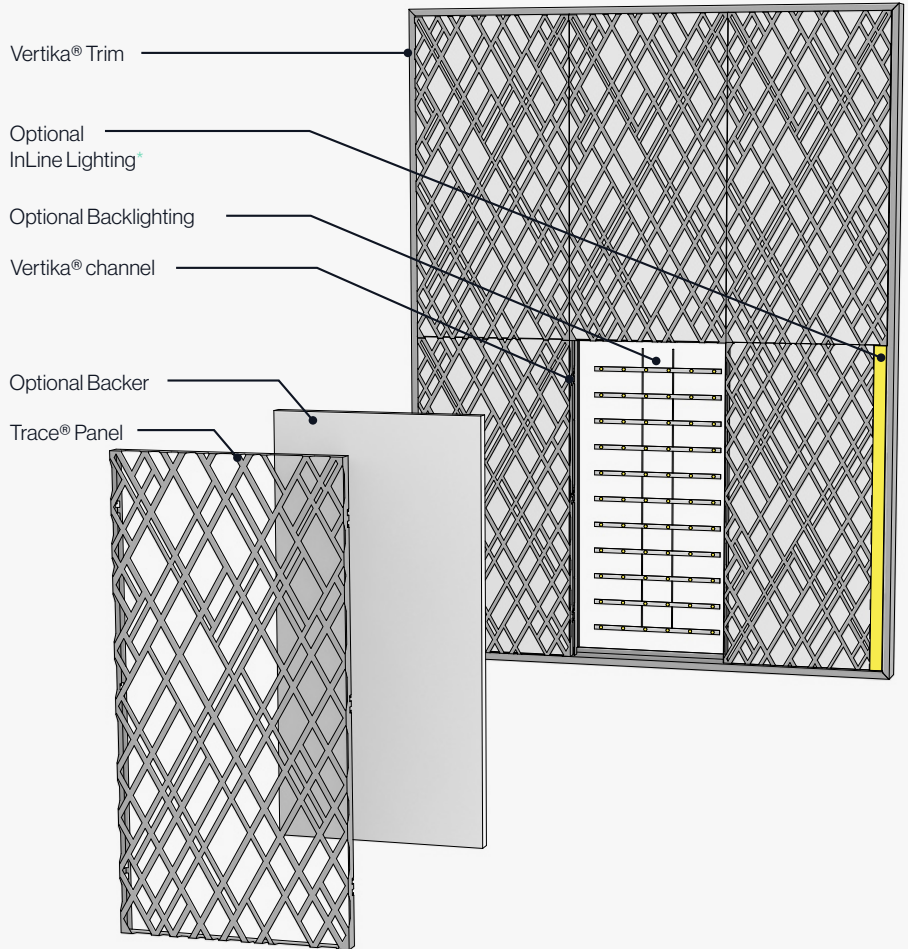

## Attachment System - Wall

Panels are easily installed or removed by sliding onto or lifting off from the system's Vertika® channel hooks.

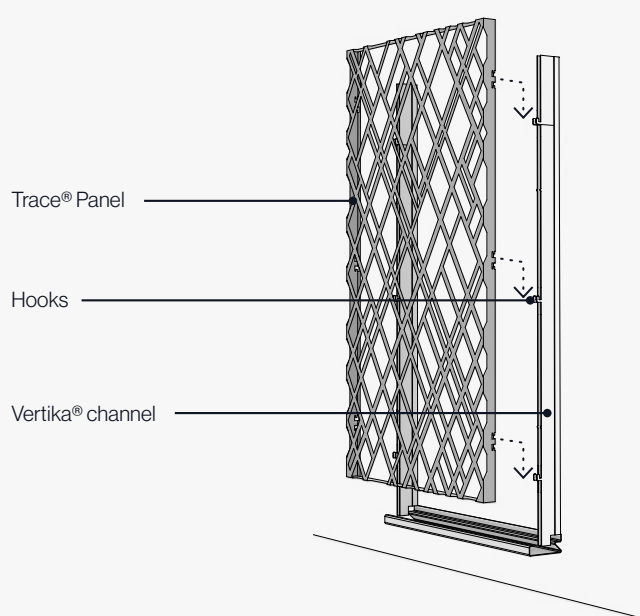

## 2 Optional Accessories

### Lighting



#### Backlighting

Arkтура Backlighting allows you to fully illuminate your ceiling and wall panel installs, creating beautiful evenly lit surfaces. These fixtures are available in high and low output versions, both dimmable. See Backlighting specs details on PAGE 15.

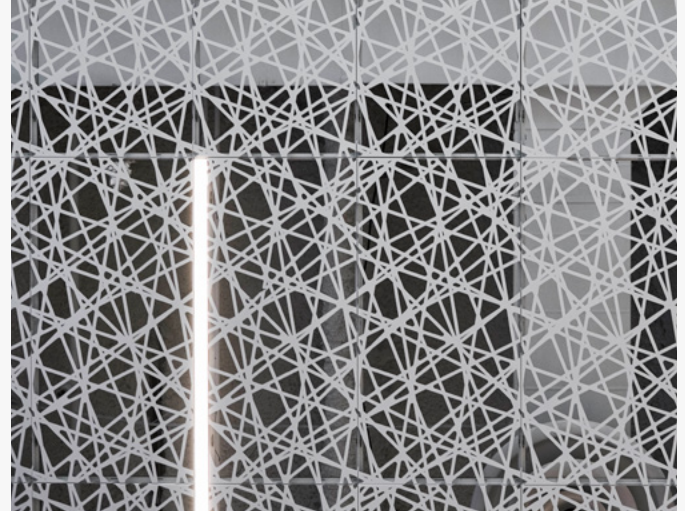

#### InLine Lighting

Our light installs below and attaches to the grid. The fixture is available in 4' increments and can be used on either 4' edge of the Trace® InLine Light panel type. See InLine Lighting specs details on PAGE 17.

### Backers



#### Soft Sound® Backer

We offer various options of Soft Sound® panel inserts to achieve a variety of NRC ratings. Please refer to our True NRC® table of ratings.

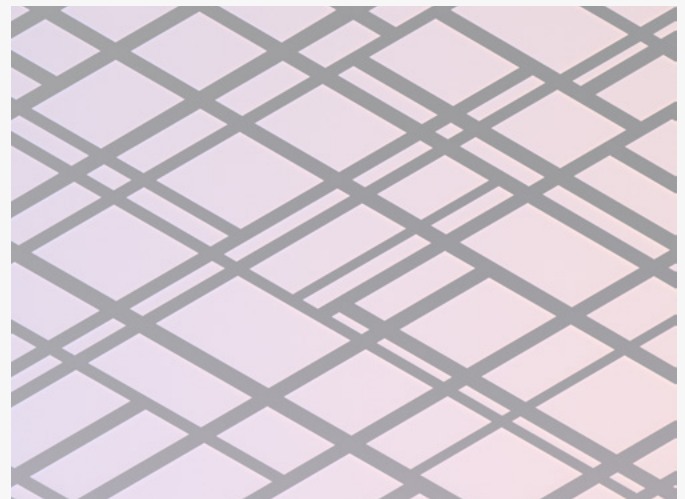

#### Translucent Backer

Our proprietary light diffusing backers can be used to create a functional or decorative lighting effect in any space.

 Illustrative images. Patterns may not match the product.

## 2 Optional Accessories

### Possible Configurations

Refer to the chart and corresponding diagrams below for available configuration options.

	No Backer	Translucent Backer	Soft Sound® Backer
No light	A	B	C
Backlight		D	
InLine	E	F	G

**i** Looking to combine backlight with acoustic performance in the same panel?  
Check out our VaporSoft® line.

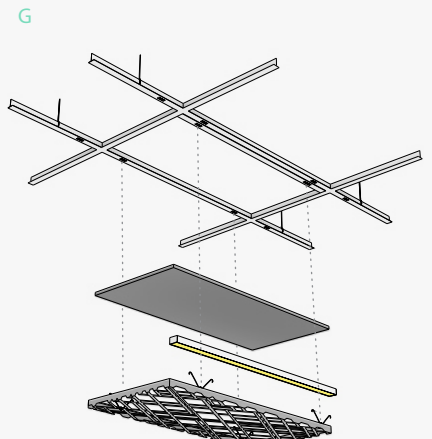
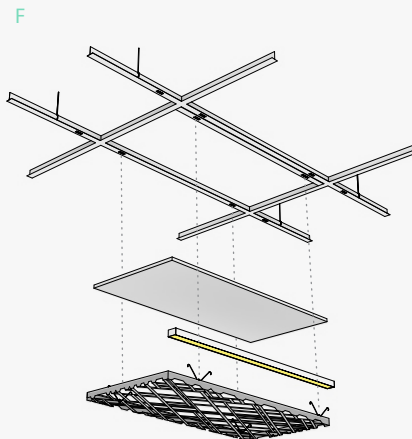
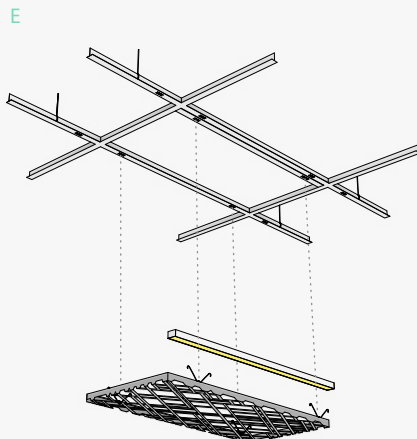
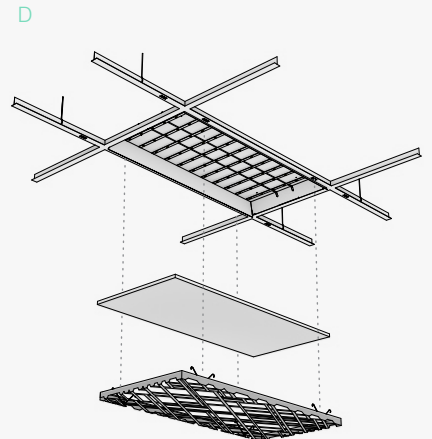
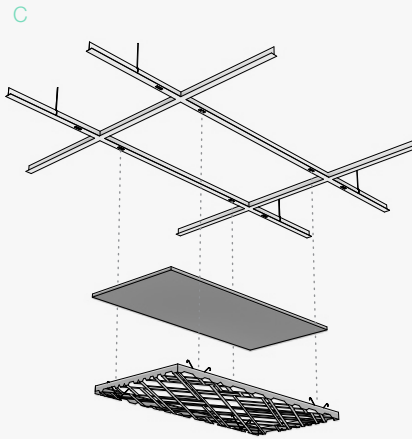
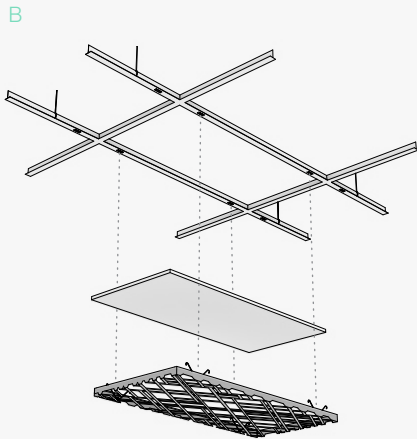
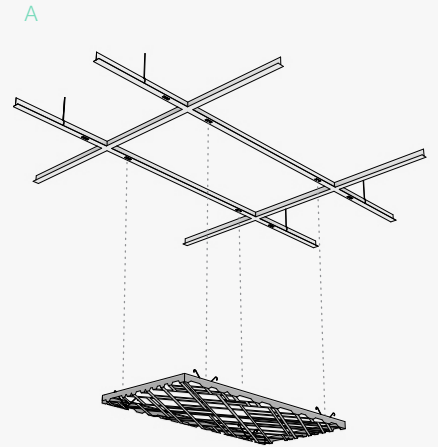

**i** Illustrative diagrams. Patterns may not match the product.

### 3 Available Finishes

#### Aluminum Panel

##### Powder Coat Standard Finish



##### Powder Coat Premium Metallic Finish



##### Custom Powder Colors

We offer premium non-stock RAL and custom color match options as well. Contact your sales rep for more information.

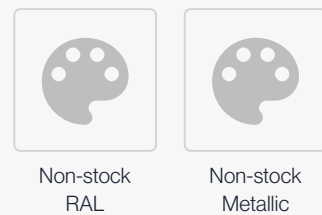

#### Premium Finish x PURE+FREEFORM

##### Patinas

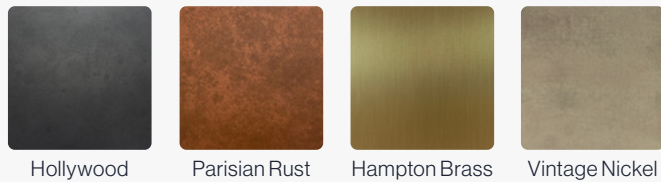

##### Wood Texture

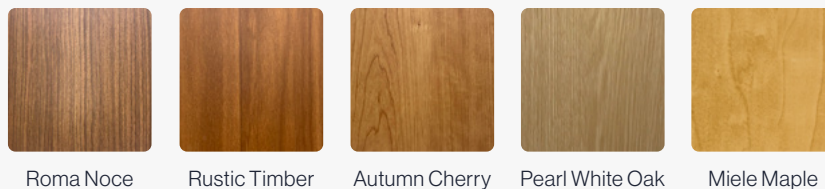

\* This color was designed to pair with Armstrong color "WH" grid and trim.

ⓘ All premium and standard finishes shown are designed for interior specifications. Products may be specified for exterior use, and with all treatments required by local code or facility, including custom color match or specialty finishes. Any changes to specification from interior standard or interior premium will result in a custom powder coat fee.

3 Available Finishes

Optional Translucent Backer

**Polycarbonate**  
Available in interior and UV stable exterior options.



Frosted

Optional Soft Sound® Backer

**Soft Sound® Vivids**  
Standard

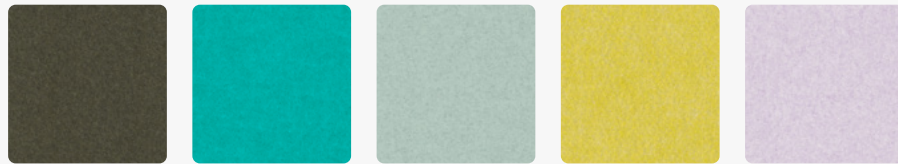

Nori

Tidal

Seafoam

Bamboo

Cosmos



Plum

Azalea

Sorbet

Buttercream

Blush

**Soft Sound® Elementals**  
Standard

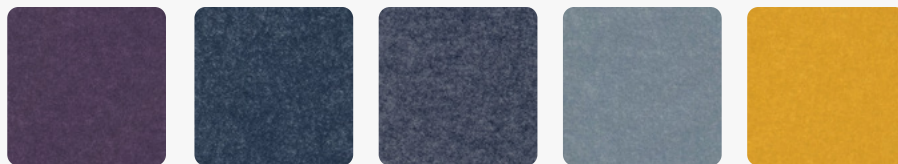

Ube

Baltic

Caspian

Cortez

Honey



Sienna

Truffle

Morel

Cypress

Pebble

⚠ Due to the nature of non-woven materials, light may pass through Soft Sound® in any thickness or color. A translucent appearance is most apparent in lighter colors and thin material when a light source is present behind the material. Arktura makes no claims or warranties about the material performing as opaque in any circumstance. To verify a products performance for light transmittance, a mockup of the specific intended use is recommended.

3 Available Finishes

Optional Soft Sound® Backer

**Soft Sound® Essentials**  
Standard

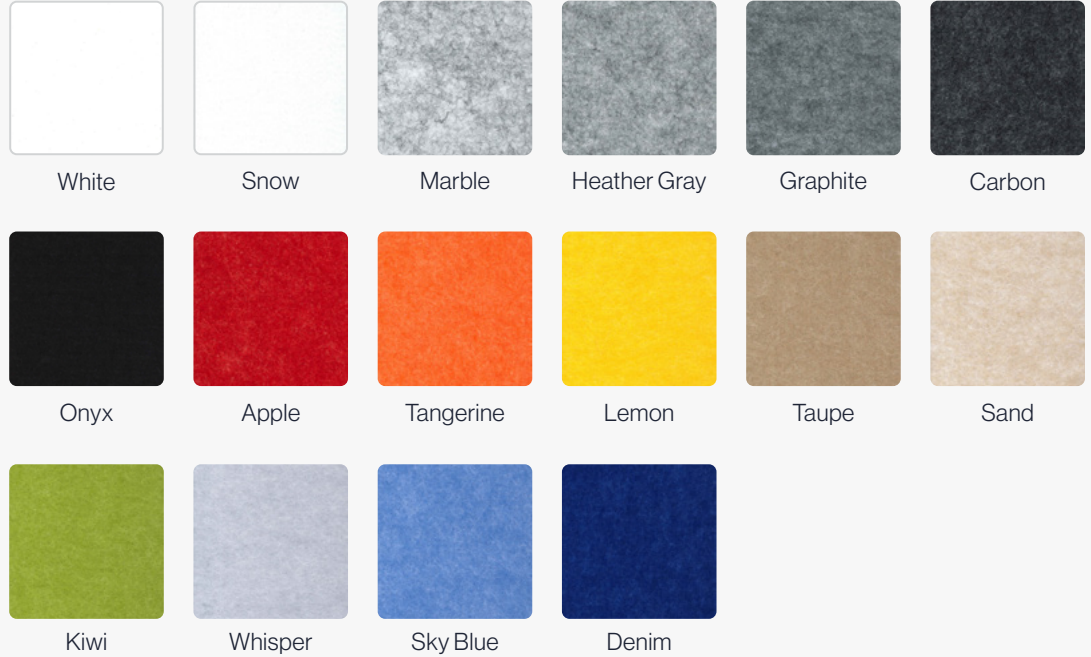

**Soft Sound® Wood Texture**  
Premium

*i* As with natural wood, variation in color and grain is expected and grain will not align across panels.

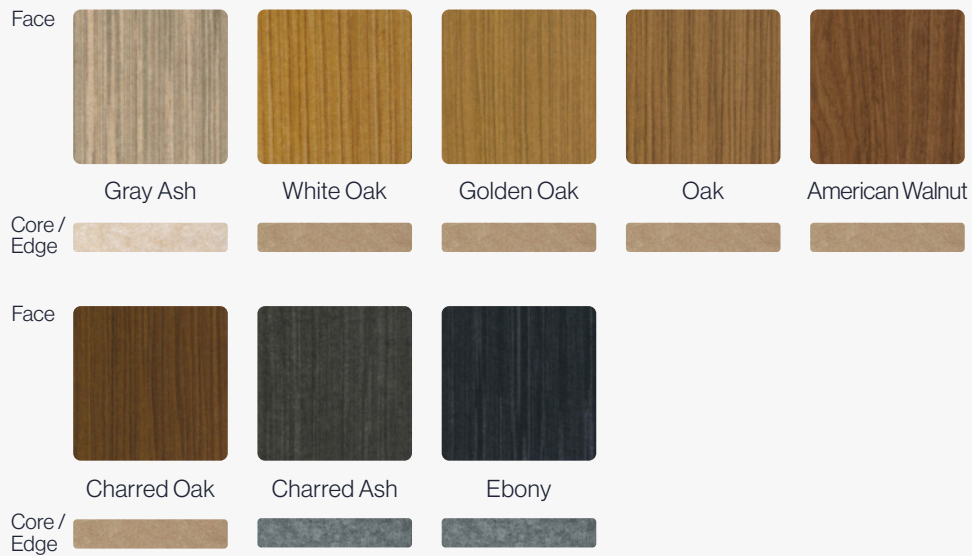

*!* Due to the nature of non-woven materials, light may pass through Soft Sound® in any thickness or color. A translucent appearance is most apparent in lighter colors and thin material when a light source is present behind the material. Arktura makes no claims or warranties about the material performing as opaque in any circumstance. To verify a products performance for light transmittance, a mockup of the specific intended use is recommended.

## 4 Product Specifications & Certifications

### System Specs

<b>Panel Size (WxHxD)</b>	2' x 4' x 1 1/2"
<b>Material</b>	Aluminum
<b>Openness in Plan</b>	62%
<b>Fire Rating</b>	ASTM E84 - Class A
<b>Acoustics</b> (with optional Soft Sound® backer)	True NRC® 0.90: Ceiling ; E-300 Method True NRC® 0.80: Wall ; F-70 Method
<b>Ceiling Attachment</b>	Torsion Grid (By Others)
<b>Wall Attachment</b>	Vertika® Wall (Refer to Vertika® Brochure)
<b>Accessibility</b>	Torsion Spring Hinge
<b>Trimmability</b>	Yes, per installation manual
<b>Accessories</b>	Acoustic Backer, Translucent Backer, Backlight, InLine Light

Patent Pending

Copyright ©2017-2021 Arktura LLC. All rights reserved.

# Arktura Backlighting Specs

Available in dimmable low and high output variations, gives you the power to illuminate spaces and create dynamic visual effects.

## Ceiling

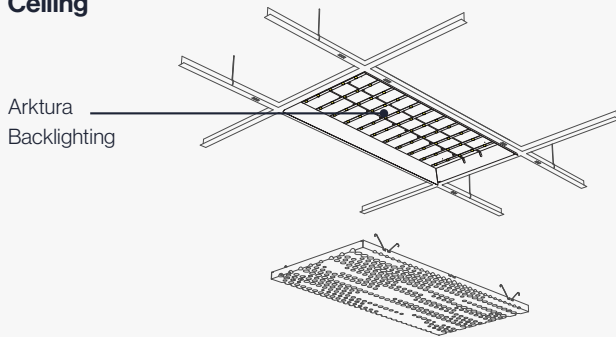

## Sections - Ceiling

Front view

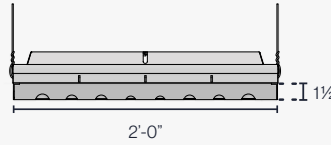

Side view

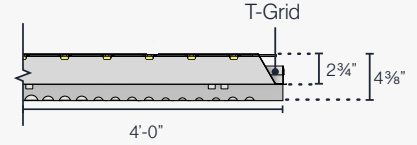

## Vertika® Wall

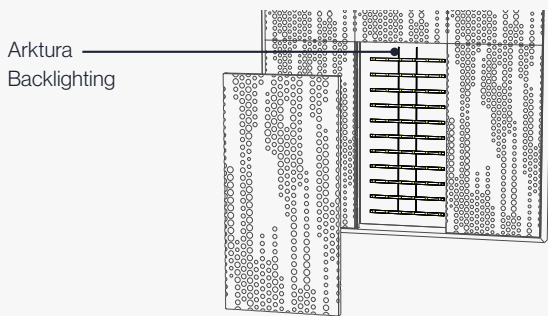

## Sections - Wall

Top view

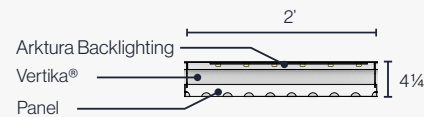

Side view

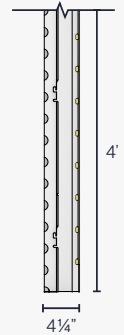

## Specs

Product Features	Arktura Backlighting Eco 2x4 Panel	Arktura Backlighting 2x4 Panel
Power Consumption	18W 24VDC .75A	65W 24VDC 2.7A
Delivered Lumens	Please Reference Next Page for Specific Openness by Pattern	
CRI	90+	
Color Temperatures	3000K, 3500K, 4000K	
Size (LxWxD)	24"x48"x3 1/4"	
Optics/Beam Angle	160° Batwing Lens Per LED	
Operating Temperature	-20C - +50°C (-4F - +122°F)	
Dimming Options	TRIAC/Phase, ELV, MLV, 0-10V, 1-10V When Paired with Arktura LED Driver	
Cable	Factory Installed Plenum Rated CL3P Cable, 16AWG 10ft Whip	
IP Rating	IP64	
Environment	Suitable for Wet, Damp or Dry locations	
Markings	ETL Listed, Complies with UL 2108 & CSA C22.2#250.13:2020 Ed.4+U1	
Lifetime	L70 - 50,000 hours	
Warranty	5 Years, Limited	

## Photometric

Located At Horizontal Angle = 0, Vertical Angle = 0

# 1 - Vertical Plane Through Horizontal Angles (0 - 180) (Through Max. Cd.)

# 2 - Horizontal Cone Through Vertical Angle (0) (Through Max. Cd.)

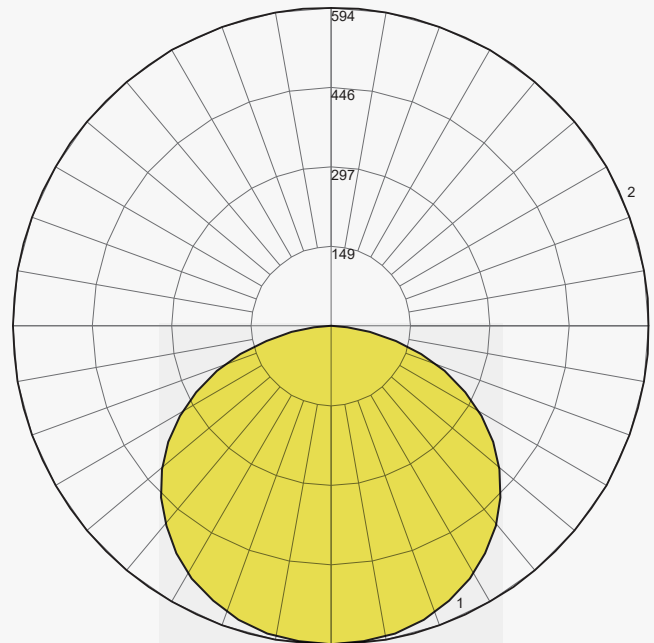

\* Represents a 40% Openness Pattern.

Illustrative images. Patterns may not match the product.

# Arktura Backlighting % Open & Lumen Output

## Backlighting % Open & Lumen Output

Product	% Open	18W Arktura Backlight Eco Lumen Output	65W Arktura Backlight Lumen Output
Vapor® Cora	68%	1176	3361
Vapor® Bloom	20%	400	1118
Vapor® Breeze	23%	457	1276
Vapor® Byte	6%	120	354
Vapor® Cluster Dense	40%	759	2124
Vapor® Cluster Sparse	10%	203	577
Vapor® Cumula	18%	362	1012
Vapor® Element 605	6%	120	354
Vapor® Element 3212	32%	621	1734
Vapor® Element 3428	34%	656	1833
Vapor® Frequency	10%	203	577
Vapor® Liana	17%	342	959
Vapor® Gradients	17%	342	959
Vapor® Sky	19%	381	1065
Vapor® Pixel	19%	381	1065
Vapor® Syntax	6%	120	354
Vapor® Trail	24%	476	1328
Vapor® Shift X	53%	965	2723
Vapor® Transit	10%	203	577
Vapor® Bond	7%	141	410
Vapor® Verve	14%	283	797
VaporSoft® Cluster Dense	40%	759	2124
VaporSoft® Cora	68%	1176	3361
VaporSoft® Trail	24%	476	1328
VaporSoft® Cluster Sparse	10%	203	577

Product	% Open	18W Arktura Backlight Eco Lumen Output	65W Arktura Backlight Lumen Output
Trace® Curved	55%	994	2811
Trace® Slide	8%	162	466
Trace® Skew	62%	1095	3112
Trace® Slant	43%	808	2266
Trace® Straight	54%	979	2767
Particle® Ion	5%	99	297
Particle® Code	9%	182	522
Particle® Phase	4%	78	241
Particle® Fuse	4%	78	241
Particle® Urban	10%	203	577
Delta Drop® 2x4 Full Pattern	12%	241	653
Delta Drop® 2x4 Half Pattern	7%	134	390
Delta Drop® 4x4 Full Pattern*	14%	538	1514
Delta Drop® 4x4 Half Pattern*	7%	268	779

\* Delta Drop® 4x4 shown with two Light Fixtures per panel.

# Arktura InLine Lighting Specs

Makes it easy to seamlessly integrate linear lighting into the design of your paneling.

## Ceiling

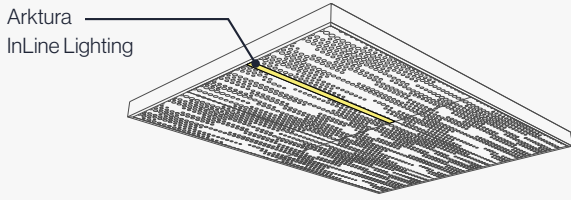

## Vertika® Wall

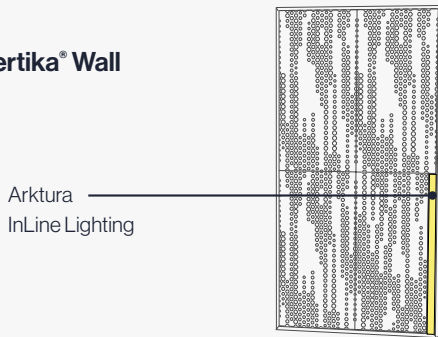

## Elevations - Ceiling

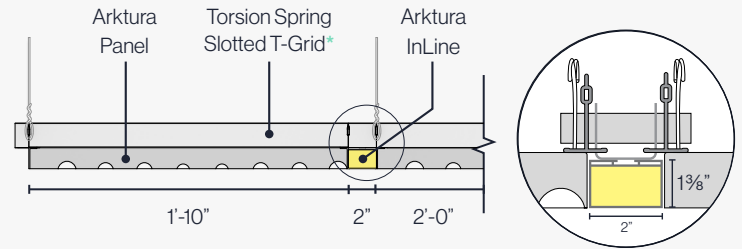

\*7301TS Prelude XL 12' HD Main Beam slotted for torsion spring.

## Top View - Wall

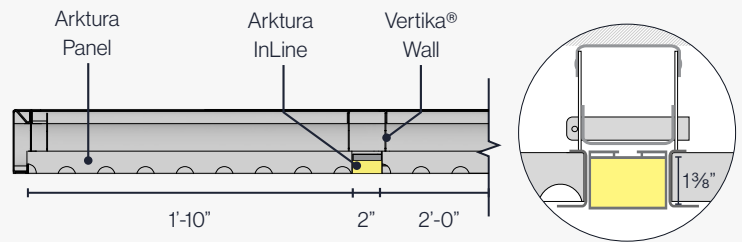

## Arktura InLine System

Description		W/ft	Fixture Watts	lm/ft	Fixture Lumens	LM/W*
4 Foot	Arktura InLine 3.5 W/ft - 4'	3.5	14	349	1396	102
	Arktura InLine 5W/ft - 4'	5	20	525	2100	114
	Arktura InLine 7W/ft - 4'	7	28	614	2457	98
	Arktura InLine 10W/ft - 4'	10	40	1021	4084	110
8 Foot	Arktura InLine 3.5W/ft - 8'	3.5	28	349	2792	102
	Arktura InLine 5W/ft - 8'	5	40	525	4200	114
	Arktura InLine 7W/ft - 8'	7	56	614	4914	98
	Arktura InLine 10W/ft - 8'	10	80	1021	8168	110

## Side - Length Options



## Photometric

Located At Horizontal Angle = 0, Vertical Angle = 0  
 #1 - Vertical Plane Through Horizontal Angles (0 - 180) (Through Max. Cd.)  
 #2 - Horizontal Cone Through Vertical Angle (0) (Through Max. Cd.)

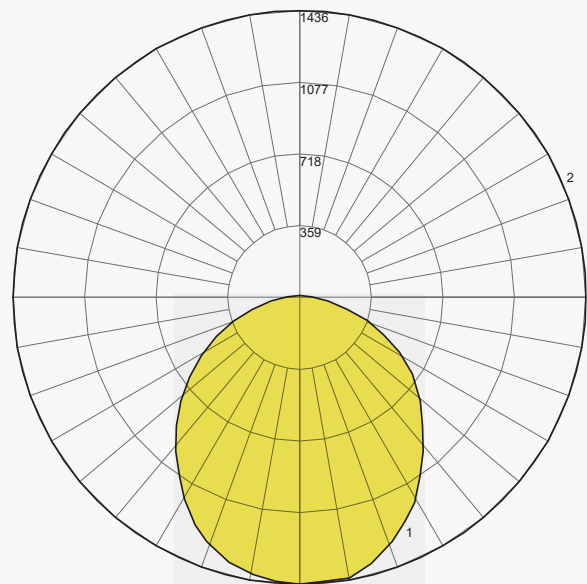

## Universal Specs

CRI	90+
Color Temperatures	3000K, 3500K, 4000K**
Operating Temperatures	-20C - +50°C (-4F - +122°F)
Dimming Options	TRIAC/Phase, ELV, MLV, 0-10V, When Paired with Arktura LED Driver
Cable	Factory Installed Plenum Rated CL3P Cable, 18AWG 4FT Cable
Environment	Indoor Locations Only
Markings	ETL Listed, Complies with UL 1598 & CSA C22.2#250.0:2021 Ed.5
Lifetime	L70 - 50,000 hours
Warranty	5 Years, Limited

Illustrative images. Patterns may not match the product.

\* Efficiency at 3500K 90CRI

\*\* Consult factory for custom color temperatures.

# Acoustic Performance

Trace® Skew with 12mm Soft Sound® backer.

**TRUE NRC™** is Arktura's commitment to providing accurate and appropriate acoustic data for our products. It represents testing based on realistic conditions for the use of our products.

FREQUENCY (Hz)	SOUND ABSORPTION COEFFICIENT (SAC)
80	0.27
100	0.41
125	0.65
160	0.78
200	0.93
250	0.92
315	0.93
400	0.94
500	0.86
630	0.69
800	0.75
1000	0.86
1250	0.87
1600	0.93
2000	0.90
2500	1.00
3150	1.00
4000	1.01
5000	1.03

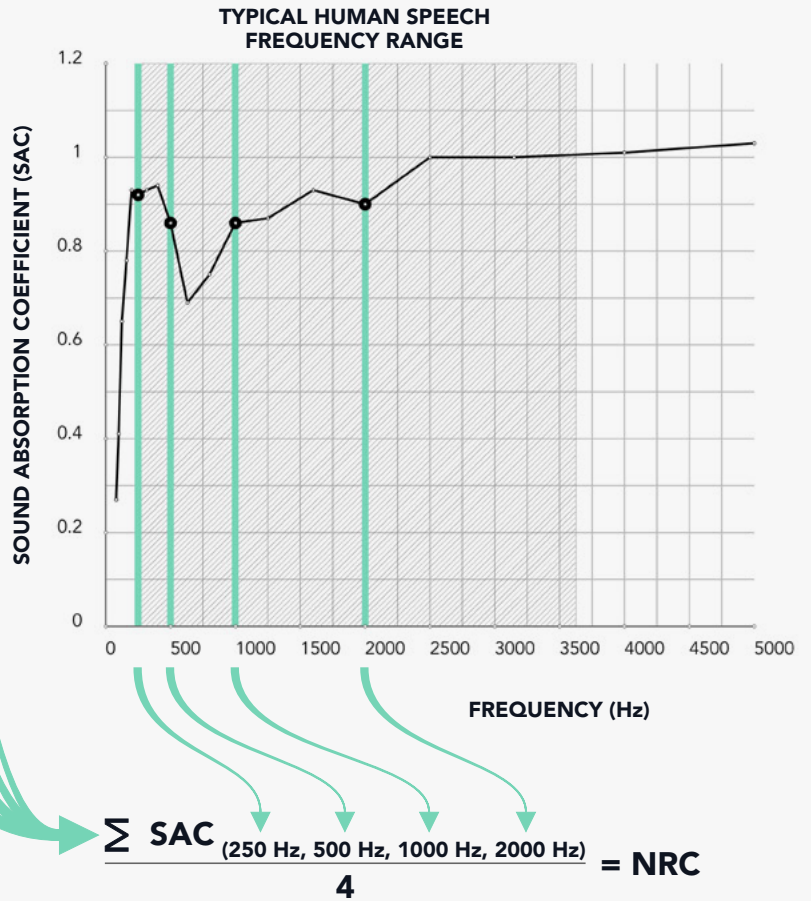

## Test Arrangements

Most popular application highlighted green.

### E300 Mounting Type - Ceiling - NRC: 0.90

In this mounting type, the specimen is an array of spaced sound absorbing panels suspended from a T-Grid system approximately 300mm (11.8") above the horizontal test surface, measured from the face of the panel. This approximates the mounting method of a typical ceiling installation. Panels were evenly distributed in a 2x4 arrangement 1/16" apart in all directions.

### F70 Mounting Type - Wall - NRC: 0.80

In this mounting type, the specimen is separated from the horizontal test surface 70mm (2.87") from the back of the panel with spacers. This is intended to simulate normal use of the product with the Vertika® wall mount system.

### F150 Mounting Type (Soft Sound® Material Only) - NRC: 0.90

In this mounting type, the specimen is separated from the surface 150mm (5.90") from the back of the panel with spacers. This is intended to simulate the raw material using spacers or spacing clips.

**i** Acoustic performance can vary widely based on how a product is mounted. Learn more about acoustic performance and how NRC is calculated at True NRC™. Testing was conducted through Intertek, Lake Forest, CA per ASTM C423.

<h2 style="color: #009688;">True NRC™: 0.90</h2> <p>SAA: 0.88</p> <p>Test Results for Ceiling Install with E300 Mounting Type</p>	<p>ACOUSTIC TESTING ASTM C423</p>
---	---------------------------------------

## Definitions

**Sound Absorption Coefficient** describes the fraction of the incident sound energy that a material absorbs. Theoretically it can vary from 0 (no energy absorbed) to 1.0 (perfect absorption with all incident sound energy absorbed).

**NRC (Noise Reduction Coefficient)** rating is the average of the sound absorption coefficients at 250, 500, 1000 and 2000 hertz. The average is rounded to the nearest multiple of 0.05.

**SAA (Sound Absorption Average)** rating is the average of the sound absorption coefficients at an octave range of 12 frequencies ranging from 200 to 2500 hertz. The average is rounded to the nearest multiple of 0.01.

# Product Line

## Design Options

Trace® introduces subtle visual interest inspired by the ephemeral beauty of mist or cirrus clouds—continuous strands weave through a grid to yield a truly elegant visual pattern. The quiet simplicity of the design makes it an ideal background for large spans and multiple rooms.

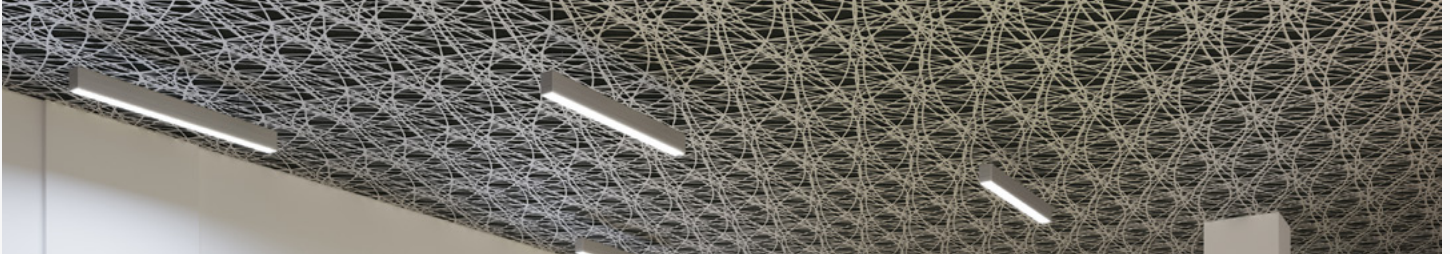

TRACE® CURVED

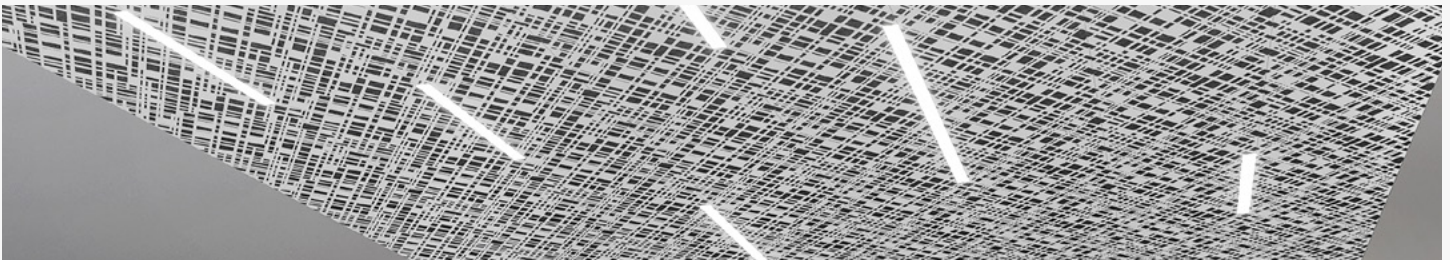

TRACE® SLANT

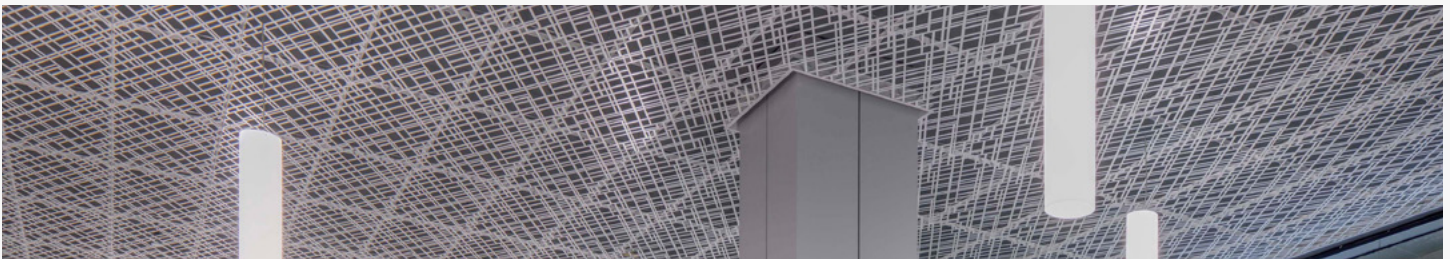

TRACE® SKEW



TRACE® STRAIGHT

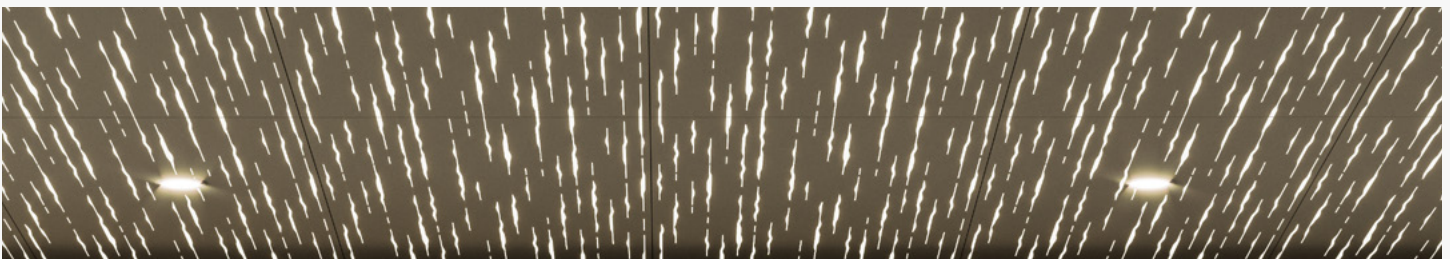

TRACE® SLIDE